

# 900 MHz Low Voltage LVPECL Clock Synthesizer

**MPC9239**

The MPC9239 is a 3.3 V compatible, PLL based clock synthesizer targeted for high performance clock generation in mid-range to high-performance telecom, networking, and computing applications. With output frequencies from 3.125 MHz to 900 MHz and the support of differential LVPECL output signals the device meets the needs of the most demanding clock applications.

## Features

- 3.125 MHz to 900 MHz synthesized clock output signal
- Differential LVPECL output
- LVCMOS compatible control inputs
- On-chip crystal oscillator for reference frequency generation
- Alternative LVCMOS compatible reference input
- 3.3 V power supply
- Fully integrated PLL
- Minimal frequency overshoot
- Serial 3-wire programming interface
- Parallel programming interface for power-up
- 28 PLCC and 32 LQFP packaging
- 28-lead and 32-lead Pb-free package available
- SiGe Technology
- Ambient temperature range 0°C to + 70°C
- Pin and function compatible to the MC12439

## Functional Description

The internal crystal oscillator uses the external quartz crystal as the basis of its frequency reference. The frequency of the internal crystal oscillator or external reference clock signal is multiplied by the PLL. The VCO within the PLL operates over a range of 800 to 1800 MHz. Its output is scaled by a divider that is configured by either the serial or parallel interfaces. The crystal oscillator frequency  $f_{XTAL}$ , the PLL feedback-divider M and the PLL post-divider N determine the output frequency.

The feedback path of the PLL is internal. The PLL adjusts the VCO output frequency to be M times the reference frequency by adjusting the VCO control voltage. Note that for some values of M (either too high or too low) the PLL will not achieve phase lock. The PLL will be stable if the VCO frequency is within the specified VCO frequency range (800 to 1800 MHz). The M-value must be programmed by the serial or parallel interface.

The PLL post-divider N is configured through either the serial or the parallel interfaces, and can provide one of four division ratios (1, 2, 4, or 8). This divider extends performance of the part while providing a 50% duty cycle. The output driver is driven differentially from the output divider, and is capable of driving a pair of transmission lines terminated 50  $\Omega$  to  $V_{CC} - 2.0$  V. The positive supply voltage for the internal PLL is separated from the power supply for the core logic and output drivers to minimize noise induced jitter.

The configuration logic has two sections: serial and parallel. The parallel interface uses the values at the M[6:0] and N[1:0] inputs to configure the internal counters. It is recommended on system reset to hold the  $\overline{P\_LOAD}$  input LOW until power becomes valid. On the LOW-to-HIGH transition of  $\overline{P\_LOAD}$ , the parallel inputs are captured. The parallel interface has priority over the serial interface. Internal pullup resistors are provided on the M[6:0] and N[1:0] inputs prevent the LVCMOS compatible control inputs from floating. The serial interface centers on a twelve bit shift register. The shift register shifts once per rising edge of the S\_CLOCK input. The serial input S\_DATA must meet setup and hold timing as specified in the AC Characteristics section of this document. The configuration latches will capture the value of the shift register on the HIGH-to-LOW edge of the S\_LOAD input. Refer to the programming section for more information. The TEST output reflects various internal node values, and is controlled by the T[2:0] bits in the serial data stream. In order to minimize the PLL jitter, it is recommended to avoid active signal on the TEST output. The PWR\_DOWN pin, when asserted, will synchronously divide the  $f_{OUT}$  by 16. The power down sequence is clocked by the PLL reference clock, thereby causing the frequency reduction to happen relatively slowly. Upon de-assertion of the PWR\_DOWN pin, the  $f_{OUT}$  input will step back up to its programmed frequency in four discrete increments.

### 900 MHz LOW VOLTAGE CLOCK SYNTHESIZER

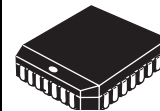

**FN SUFFIX**  
28-LEAD PLCC PACKAGE  
CASE 776-02

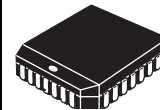

**EI SUFFIX**  
28-LEAD PLCC PACKAGE  
Pb-FREE PACKAGE  
CASE 776-02



**FA SUFFIX**  
32-LEAD LQFP PACKAGE  
CASE 873A-04



**AC SUFFIX**  
32-LEAD LQFP PACKAGE  
Pb-FREE PACKAGE  
CASE 873A-04

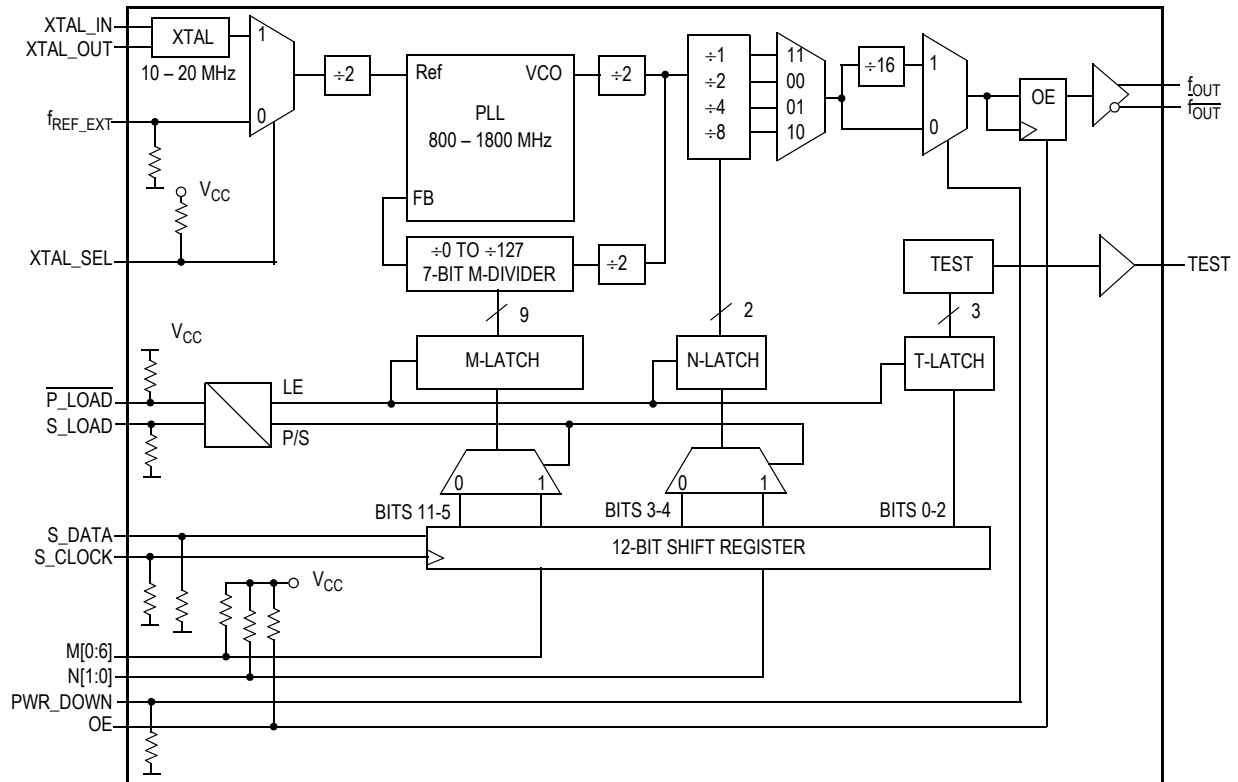

Figure 1. MPC9239 Logic Diagram

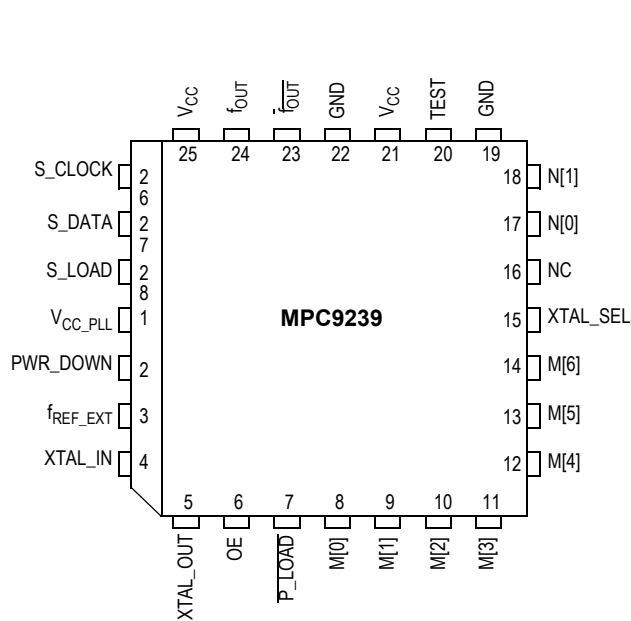

Figure 2. MPC9239 28-Lead PLCC Pinout (Top View)

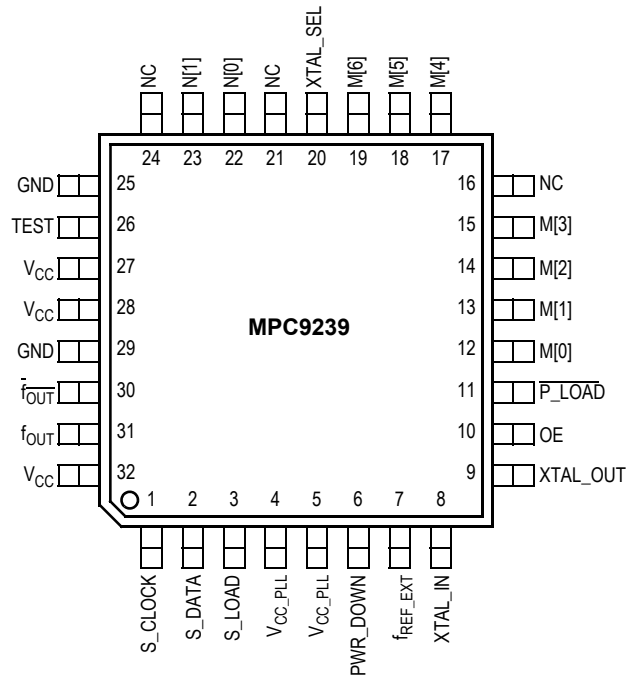

Figure 3. MPC9239 32-Lead LQFP Pinout (Top View)

Table 1. Pin Configurations

| Pin                              | I/O    | Default | Type     | Function  |
|----------------------------------|--------|---------|----------|---|
| XTAL_IN, XTAL_OUT                |        |         | Analog   | Crystal oscillator interface.   |
| $f_{REF\_EXT}$                   | Input  | 0       | LVC MOS  | Alternative PLL reference input.  |
| $f_{OUT}$ , $\overline{f_{OUT}}$ | Output |         | LVPECL   | Differential clock output.  |
| TEST                             | Output |         | LVC MOS  | Test and device diagnosis output.   |
| XTAL_SEL                         | Input  | 1       | LVC MOS  | PLL reference select input.   |
| PWR_DOWN                         | Input  | 0       | LVC MOS  | Configuration input for power down mode. Assertion (deassertion) of power down will decrease (increase) the output frequency by a ratio of 16 in 4 discrete steps. PWR_DOWN assertion (deassertion) is synchronous to the input reference clock.  |
| S_LOAD                           | Input  | 0       | LVC MOS  | Serial configuration control input. This inputs controls the loading of the configuration latches with the contents of the shift register. The latches will be transparent when this signal is high, thus the data must be stable on the high-to-low transition.  |
| $\overline{P\_LOAD}$             | Input  | 1       | LVC MOS  | Parallel configuration control input. this input controls the loading of the configuration latches with the content of the parallel inputs (M and N). The latches will be transparent when this signal is low, thus the parallel data must be stable on the low-to-high transition of $\overline{P\_LOAD}$ . $\overline{P\_LOAD}$ is state sensitive. |
| S_DATA                           | Input  | 0       | LVC MOS  | Serial configuration data input.  |
| S_CLOCK                          | Input  | 0       | LVC MOS  | Serial configuration clock input.   |
| M[0:6]                           | Input  | 1       | LVC MOS  | Parallel configuration for PLL feedback divider (M).<br>M is sampled on the low-to-high transition of $\overline{P\_LOAD}$ .  |
| N[1:0]                           | Input  | 1       | LVC MOS  | Parallel configuration for Post-PLL divider (N).<br>N is sampled on the low-to-high transition of $\overline{P\_LOAD}$ .  |
| OE                               | Input  | 1       | LVC MOS  | Output enable (active high).<br>The output enable is synchronous to the output clock to eliminate the possibility of runt pulses on the $f_{OUT}$ output. OE = L low stops $f_{OUT}$ in the logic low stat ( $f_{OUT} = L$ , $\overline{f_{OUT}} = H$ ).  |
| GND                              | Supply |         | Ground   | Negative power supply (GND).  |
| $V_{CC}$                         | Supply |         | $V_{CC}$ | Positive power supply for I/O and core. All $V_{CC}$ pins must be connected to the positive power supply for correct operation.   |
| $V_{CC\_PLL}$                    | Supply |         | $V_{CC}$ | PLL positive power supply (analog power supply).  |
| NC                               |        |         |          | Do not connect.   |

Table 2. Output Frequency Range and PLL Post-Divider N

| PWR_DOWN | N |   | VCO Output Frequency Division | $f_{OUT}$ Frequency Range |
|----------|---|---|-------------------------------|---------------------------|
|          | 1 | 0 |                               |                           |
| 0        | 0 | 0 | 2                             | 200 – 450 MHz             |
| 0        | 0 | 1 | 4                             | 100 – 225 MHz             |
| 0        | 1 | 0 | 8                             | 50 – 112.5 MHz            |
| 0        | 1 | 1 | 1                             | 400 – 900 MHz             |
| 1        | 0 | 0 | 32                            | 12.5 – 28.125 MHz         |
| 1        | 0 | 1 | 64                            | 6.25 – 14.0625 MHz        |
| 1        | 1 | 0 | 128                           | 3.125 – 7.03125 MHz       |
| 1        | 1 | 1 | 16                            | 25 – 56.25 MHz            |

Table 3. Function Table

| Input    | 0  | 1                        |
|----------|--|--------------------------|
| XTAL_SEL | $f_{REF\_EXT}$   | XTAL interface           |
| OE       | Outputs disabled. $f_{OUT}$ is stopped in the logic low state ( $f_{OUT} = L$ , $f_{\overline{OUT}} = H$ ) | Outputs enabled          |
| PWR_DOWN | Output divider $\div 1$  | Output divider $\div 16$ |

Table 4. General Specifications

| Symbol        | Characteristics  | Min  | Typ                                  | Max                                  | Unit          | Condition  |
|---------------|--|------|--------------------------------------|--------------------------------------|---------------|--|
| $V_{TT}$      | Output Termination Voltage   |      | $V_{CC} - 2$                         |                                      | V             |  |
| MM            | ESD Protection (Machine Model)   | 200  |                                      |                                      | V             |  |
| HBM           | ESD Protection (Human Body Model)  | 2000 |                                      |                                      | V             |  |
| LU            | Latch-Up Immunity  | 200  |                                      |                                      | mA            |  |
| $C_{IN}$      | Input Capacitance  |      | 4.0                                  |                                      | pF            | Inputs   |
| $\theta_{JA}$ | LQFP 32 Thermal Resistance Junction to Ambient<br>JESD 51-3, single layer test board |      | 83.1<br>73.3<br>68.9<br>63.8<br>57.4 | 86.0<br>75.4<br>70.9<br>65.3<br>59.6 | $^{\circ}C/W$ | Natural convection<br>100 ft/min<br>200 ft/min<br>400 ft/min<br>800 ft/min |
|               | JESD 51-6, 2S2P multilayer test board  |      | 59.0<br>54.4<br>52.5<br>50.4<br>47.8 | 60.6<br>55.7<br>53.8<br>51.5<br>48.8 | $^{\circ}C/W$ | Natural convection<br>100 ft/min<br>200 ft/min<br>400 ft/min<br>800 ft/min |
| $\theta_{JC}$ | LQFP 32 Thermal Resistance Junction to Case  |      | 23.0                                 | 26.3                                 | $^{\circ}C/W$ | MIL-SPEC 883E<br>Method 1012.1   |

Table 5. Absolute Maximum Ratings<sup>(1)</sup>

| Symbol    | Characteristics     | Min  | Max            | Unit        | Condition |
|-----------|---------------------|------|----------------|-------------|-----------|
| $V_{CC}$  | Supply Voltage      | -0.3 | 3.9            | V           |           |
| $V_{IN}$  | DC Input Voltage    | -0.3 | $V_{CC} + 0.3$ | V           |           |
| $V_{OUT}$ | DC Output Voltage   | -0.3 | $V_{CC} + 0.3$ | V           |           |
| $I_{IN}$  | DC Input Current    |      | $\pm 20$       | mA          |           |
| $I_{OUT}$ | DC Output Current   |      | $\pm 50$       | mA          |           |
| $T_S$     | Storage Temperature | -65  | 125            | $^{\circ}C$ |           |

1. Absolute maximum continuous ratings are those maximum values beyond which damage to the device may occur. Exposure to these conditions or conditions beyond those indicated may adversely affect device reliability. Functional operation at absolute-maximum-rated conditions is not implied.

**Table 6. DC Characteristics** ( $V_{CC} = 3.3 \text{ V} \pm 5\%$ ,  $T_A = 0^\circ\text{C}$  to  $+70^\circ\text{C}$ )

| Symbol  | Characteristics                    | Min             | Typ | Max             | Unit          | Condition                  |
|---|------------------------------------|-----------------|-----|-----------------|---------------|----------------------------|
| LVCMOS Control Inputs ( $f_{REF\_EXT}$ , PWR_DOWN, XTAL_SEL, P_LOAD, S_LOAD, S_DATA, S_CLOCK, M[0:8], N[0:1], OE) |                                    |                 |     |                 |               |                            |
| $V_{IH}$  | Input High Voltage                 | 2.0             |     | $V_{CC} + 0.3$  | V             | LVCMOS                     |
| $V_{IL}$  | Input Low Voltage                  |                 |     | 0.8             | V             | LVCMOS                     |
| $I_{IN}$  | Input Current <sup>(1)</sup>       |                 |     | $\pm 200$       | $\mu\text{A}$ | $V_{IN} = V_{CC}$ or GND   |
| Differential Clock Output $f_{OUT}$ <sup>(2)</sup>  |                                    |                 |     |                 |               |                            |
| $V_{OH}$  | Output High Voltage <sup>(3)</sup> | $V_{CC} - 1.02$ |     | $V_{CC} - 0.74$ | V             | LVPECL                     |
| $V_{OL}$  | Output Low Voltage <sup>(3)</sup>  | $V_{CC} - 1.95$ |     | $V_{CC} - 1.60$ | V             | LVPECL                     |
| Test and Diagnosis Output TEST  |                                    |                 |     |                 |               |                            |
| $V_{OH}$  | Output High Voltage <sup>(3)</sup> | 2.0             |     |                 | V             | $I_{OH} = -0.8 \text{ mA}$ |
| $V_{OL}$  | Output Low Voltage <sup>(3)</sup>  |                 |     | 0.55            | V             | $I_{OL} = 0.8 \text{ mA}$  |
| Supply Current  |                                    |                 |     |                 |               |                            |
| $I_{CC\_PLL}$   | Maximum PLL Supply Current         |                 |     | 20              | mA            | $V_{CC\_PLL}$ Pins         |
| $I_{CC}$  | Maximum Supply Current             |                 | 62  | 100             | mA            | All $V_{CC}$ Pins          |

1. Inputs have pull-down resistors affecting the input current.

2. Outputs terminated  $50 \Omega$  to  $V_{TT} = V_{CC} - 2 \text{ V}$ .

3. The MPC9239 TEST output levels are compatible to the MC12429 output levels. The MPC9239 is capable of driving  $25 \Omega$  loads.

**Table 7. AC Characteristics** ( $V_{CC} = 3.3 \text{ V} \pm 5\%$ ,  $T_A = 0^\circ\text{C}$  to  $+70^\circ\text{C}$ )<sup>(1)</sup>

| Symbol         | Characteristics   | Min  | Typ                     | Max                        | Unit                     | Condition    |
|----------------|---|--|-------------------------|----------------------------|--------------------------|--------------|
| $f_{XTAL}$     | Crystal Interface Frequency Range                           | 10   |                         | 20                         | MHz                      |              |
| $f_{VCO}$      | VCO Frequency Range <sup>(2)</sup>                          | 800  |                         | 1800                       | MHz                      |              |
| $f_{MAX}$      | Output Frequency  | N = 11 ( $\div 1$ )<br>N = 00 ( $\div 2$ )<br>N = 01 ( $\div 4$ )<br>N = 10 ( $\div 8$ ) | 400<br>300<br>100<br>50 | 900<br>450<br>225<br>112.5 | MHz<br>MHz<br>MHz<br>MHz | PWR_DOWN = 0 |
| $f_{S\_CLOCK}$ | Serial Interface Programming Clock Frequency <sup>(3)</sup> | 0  |                         | 10                         | MHz                      |              |
| $t_{P\_MIN}$   | Minimum Pulse Width (S_LOAD, P_LOAD)                        | 50   |                         |                            | ns                       |              |
| DC             | Output Duty Cycle   | 45   | 50                      | 55                         | %                        |              |
| $t_r, t_f$     | Output Rise/Fall Time                                       | 0.05   |                         | 0.3                        | ns                       | 20% to 80%   |
| $t_s$          | Setup Time  | S_DATA to S_CLOCK<br>S_CLOCK to S_LOAD<br>M, N to P_LOAD                                 | 20<br>20<br>20          |                            | ns<br>ns<br>ns           |              |
| $t_s$          | Hold Time   | S_DATA to S_CLOCK<br>M, N to P_LOAD  | 20<br>20                |                            | ns<br>ns                 |              |
| $t_{JIT(CC)}$  | Cycle-to-Cycle Jitter                                       | N = 11 ( $\div 1$ )<br>N = 00 ( $\div 2$ )<br>N = 01 ( $\div 4$ )<br>N = 10 ( $\div 8$ ) |                         | 60<br>90<br>120<br>160     | ps<br>ps<br>ps<br>ps     |              |
| $t_{JIT(PER)}$ | Period Jitter   | N = 11 ( $\div 1$ )<br>N = 00 ( $\div 2$ )<br>N = 01 ( $\div 4$ )<br>N = 10 ( $\div 8$ ) |                         | 40<br>65<br>90<br>120      | ps<br>ps<br>ps<br>ps     |              |
| $t_{LOCK}$     | Maximum PLL Lock Time                                       |  |                         | 10                         | ms                       |              |

1. AC characteristics apply for parallel output termination of  $50 \Omega$  to  $V_{TT}$ .

2. The input frequency  $f_{XTAL}$  and the PLL feedback divider M must match the VCO frequency range:  $f_{VCO} = f_{XTAL} \cdot 2 \cdot M$ .

3. The frequency of S\_CLOCK is limited to 10 MHz in serial programming mode. S\_CLOCK can be switched at higher frequencies when used as test clock in test mode 6. Refer to the application section for more details.

Table 8. MPC9239 Frequency Operating Range (in MHz)

| M   | M[6:0]  | VCO frequency for a crystal interface frequency of |        |        |        |        |        | Output frequency for $f_{XTAL} = 16$ MHz and for N = |     |     |     |
|-----|---------|--|--------|--------|--------|--------|--------|--|-----|-----|-----|
|     |         | 10 MHz   | 12 MHz | 14 MHz | 16 MHz | 18 MHz | 20 MHz | 1  | 2   | 4   | 8   |
| 20  | 0010100 |  |        |        |        |        | 800    |  |     |     |     |
| 21  | 0010101 |  |        |        |        |        | 840    |  |     |     |     |
| 22  | 0010110 |  |        |        |        |        | 880    |  |     |     |     |
| 23  | 0010111 |  |        |        |        | 828    | 920    |  |     |     |     |
| 24  | 0011000 |  |        |        |        | 864    | 960    |  |     |     |     |
| 25  | 0011001 |  |        |        | 800    | 900    | 1000   | 400  | 200 | 100 | 50  |
| 26  | 0011010 |  |        |        | 832    | 936    | 1040   | 416  | 208 | 104 | 52  |
| 27  | 0011011 |  |        |        | 864    | 972    | 1080   | 432  | 216 | 108 | 54  |
| 28  | 0011100 |  |        | 812    | 896    | 1008   | 1120   | 448  | 224 | 112 | 56  |
| 29  | 0011101 |  |        | 840    | 928    | 1044   | 1160   | 464  | 232 | 116 | 58  |
| 30  | 0011110 |  |        | 875    | 960    | 1080   | 1200   | 480  | 240 | 120 | 60  |
| 31  | 0011111 |  |        | 868    | 992    | 1116   | 1240   | 496  | 248 | 124 | 62  |
| 32  | 0100000 |  |        | 896    | 1024   | 1152   | 1280   | 512  | 256 | 128 | 64  |
| 33  | 0100001 |  |        | 924    | 1056   | 1188   | 1320   | 528  | 264 | 132 | 66  |
| 34  | 0100010 |  | 816    | 952    | 1088   | 1224   | 1360   | 544  | 272 | 136 | 68  |
| 35  | 0100011 |  | 840    | 980    | 1120   | 1260   | 1400   | 560  | 280 | 140 | 70  |
| 36  | 0100100 |  | 864    | 1008   | 1152   | 1296   | 1440   | 576  | 288 | 144 | 72  |
| 37  | 0100101 |  | 888    | 1036   | 1184   | 1332   | 1480   | 592  | 296 | 148 | 74  |
| 38  | 0100110 |  | 912    | 1064   | 1216   | 1368   | 1520   | 608  | 304 | 152 | 76  |
| 39  | 0100111 |  | 936    | 1092   | 1248   | 1404   | 1560   | 624  | 312 | 156 | 78  |
| 40  | 0101000 | 800  | 960    | 1120   | 1280   | 1440   | 1600   | 640  | 320 | 160 | 80  |
| 41  | 0101001 | 820  | 984    | 1148   | 1312   | 1476   | 1640   | 656  | 328 | 164 | 82  |
| 42  | 0101010 | 840  | 1008   | 1176   | 1344   | 1512   | 1680   | 672  | 336 | 168 | 84  |
| 43  | 0101011 | 860  | 1032   | 1204   | 1376   | 1548   | 1720   | 688  | 344 | 172 | 86  |
| 44  | 0101100 | 880  | 1056   | 1232   | 1408   | 1584   | 1760   | 704  | 352 | 176 | 88  |
| 45  | 0101101 | 900  | 1080   | 1260   | 1440   | 1620   | 1800   | 720  | 360 | 180 | 90  |
| 46  | 0101110 | 920  | 1104   | 1288   | 1472   | 1656   |        | 736  | 368 | 184 | 92  |
| 47  | 0101111 | 940  | 1128   | 1316   | 1504   | 1692   |        | 752  | 376 | 188 | 94  |
| 48  | 0110000 | 960  | 1152   | 1344   | 1536   | 1728   |        | 768  | 384 | 192 | 96  |
| 49  | 0110001 | 980  | 1176   | 1372   | 1568   | 1764   |        | 784  | 392 | 196 | 98  |
| 50  | 0110010 | 1000   | 1200   | 1400   | 1600   | 1800   |        | 800  | 400 | 200 | 100 |
| 51  | 0110011 | 1020   | 1224   | 1428   | 1632   |        |        | 816  | 408 | 204 | 102 |
| 52  | 0110100 | 1040   | 1248   | 1456   | 1664   |        |        | 832  | 416 | 208 | 104 |
| 53  | 0110101 | 1060   | 1272   | 1484   | 1696   |        |        | 848  | 424 | 212 | 106 |
| 54  | 0110110 | 1080   | 1296   | 1512   | 1728   |        |        | 864  | 432 | 216 | 108 |
| 55  | 0110111 | 1100   | 1320   | 1540   | 1760   |        |        | 880  | 440 | 220 | 110 |
| 56  | 0111000 | 1120   | 1344   | 1568   | 1792   |        |        | 896  | 448 | 224 | 112 |
| 57  | 0111001 | 1140   | 1368   | 1596   |        |        |        |  |     |     |     |
| 58  | 0111010 | 1160   | 1392   | 1624   |        |        |        |  |     |     |     |
| 59  | 0111011 | 1180   | 1416   | 1652   |        |        |        |  |     |     |     |
| 60  | 0111100 | 1200   | 1440   | 1680   |        |        |        |  |     |     |     |
| 61  | 0111101 | 1220   | 1488   | 1736   |        |        |        |  |     |     |     |
| 62  | 0111110 | 1260   | 1512   | 1764   |        |        |        |  |     |     |     |
| 63  | 0111111 | 1260   | 1512   | 1764   |        |        |        |  |     |     |     |
| 64  | 1000000 | 1280   | 1536   | 1792   |        |        |        |  |     |     |     |
| ... |         | ...  | ...    | ...    |        |        |        |  |     |     |     |

### Programming the MPC9239

Programming the MPC9239 amounts to properly configuring the internal PLL dividers to produce the desired synthesized frequency at the output. The output frequency can be represented by this formula:

$$f_{OUT} = (f_{XTAL} \div 2) \cdot (M \cdot 4) \div (N \cdot 2) \text{ or} \quad (1)$$

$$f_{OUT} = f_{XTAL} \cdot M \div N \quad (2)$$

where  $f_{XTAL}$  is the crystal frequency, M is the PLL feedback-divider and N is the PLL post-divider. The input frequency and the selection of the feedback divider M is limited by the VCO-frequency range.  $f_{XTAL}$  and M must be configured to match the VCO frequency range of 800 to 1800 MHz in order to achieve stable PLL operation:

$$M_{MIN} = f_{VCO,MIN} \div (2 \cdot f_{XTAL}) \text{ and} \quad (3)$$

$$M_{MAX} = f_{VCO,MAX} \div (2 \cdot f_{XTAL}) \quad (4)$$

For instance, the use of a 16 MHz input frequency requires the configuration of the PLL feedback divider between  $M = 25$  and  $M = 56$ . Table 8 shows the usable VCO frequency and M divider range for other example input frequencies.

Assuming that a 16 MHz input frequency is used, equation (2) reduces to:

$$f_{OUT} = 16 M \div N$$

Substituting N for the four available values for N (1, 2, 4, 8) yields:

**Table 9. Output Frequency Range for  $f_{XTAL} = 10$  MHz**

| N |   |       | $f_{OUT}$ | $f_{OUT}$ Range | $f_{OUT}$ Step |
|---|---|-------|-----------|-----------------|----------------|
| 1 | 0 | Value |           |                 |                |
| 0 | 0 | 2     | 8-M       | 200–450 MHz     | 8 MHz          |
| 0 | 1 | 4     | 4-M       | 100–225 MHz     | 4 MHz          |
| 1 | 0 | 8     | 2-M       | 50–112.5 MHz    | 2 MHz          |
| 1 | 1 | 1     | 16-M      | 400–900 MHz     | 16 MHz         |

### Example Calculation for an 16 MHz Input Frequency

For example, if an output frequency of 384 MHz was desired, the following steps would be taken to identify the appropriate M and N values. 384 MHz falls within the frequency range set by an N value of 2, so  $N[1:0]=00$ . For  $N = 2$ ,  $f_{OUT} = 8 \cdot M$ , and  $M = f_{OUT} \div 8$ . Therefore,  $M = 384 \div 8 = 48$ , so  $M[6:0] = 0110000$ . Following this procedure a user can generate any whole frequency between 50 MHz and 900 MHz. The size of the programmable frequency steps will be equal to:

$$f_{STEP} = f_{XTAL} \div N$$

### Using the Parallel and Serial Interface

The M and N counters can be loaded either through a parallel or serial interface. The parallel interface is controlled via the  $\overline{P\_LOAD}$  signal such that a LOW to HIGH transition will latch the information present on the  $M[6:0]$  and  $N[1:0]$  inputs into the M and N counters. When the  $\overline{P\_LOAD}$  signal

is LOW the input latches will be transparent and any changes on the  $M[6:0]$  and  $N[1:0]$  inputs will affect the  $f_{OUT}$  output pair. To use the serial port the  $S\_CLOCK$  signal samples the information on the  $S\_DATA$  line and loads it into a 12 bit shift register. Note that the  $\overline{P\_LOAD}$  signal must be HIGH for the serial load operation to function. The Test register is loaded with the first three bits, the N register with the next two, and the M register with the final eight bits of the data stream on the  $S\_DATA$  input. For each register the most significant bit is loaded first (T2, N1, and M6). A pulse on the  $S\_LOAD$  pin after the shift register is fully loaded will transfer the divide values into the counters. The HIGH to LOW transition on the  $S\_LOAD$  input will latch the new divide values into the counters. Figure 4 illustrates the timing diagram for both a parallel and a serial load of the MPC9239 synthesizer.

$M[6:0]$  and  $N[1:0]$  are normally specified once at power-up through the parallel interface, and then possibly again through the serial interface. This approach allows the application to come up at one frequency and then change or fine-tune the clock as the ability to control the serial interface becomes available.

### Using the Test and Diagnosis Output TEST

The TEST output provides visibility for one of the several internal nodes as determined by the  $T[2:0]$  bits in the serial configuration stream. It is not configurable through the parallel interface. Although it is possible to select the node that represents  $f_{OUT}$ , the LVCMOS output is not able to toggle fast enough for higher output frequencies and should only be used for test and diagnosis.

The T2, T1, and T0 control bits are preset to '000' when  $\overline{P\_LOAD}$  is LOW so that the PECL  $f_{OUT}$  outputs are as jitter-free as possible. Any active signal on the TEST output pin will have detrimental effects on the jitter of the PECL output pair. In normal operations, jitter specifications are only guaranteed if the TEST output is static. The serial configuration port can be used to select one of the alternate functions for this pin.

Most of the signals available on the TEST output pin are useful only for performance verification of the MPC9239 itself. However, the PLL bypass mode may be of interest at the board level for functional debug. When  $T[2:0]$  is set to 110 the MPC9239 is placed in PLL bypass mode. In this mode the  $S\_CLOCK$  input is fed directly into the M and N dividers. The N divider drives the  $f_{OUT}$  differential pair and the M counter drives the TEST output pin. In this mode the  $S\_CLOCK$  input could be used for low speed board level functional test or debug. Bypassing the PLL and driving  $f_{OUT}$  directly gives the user more control on the test clocks sent through the clock tree shows the functional setup of the PLL bypass mode. Because the  $S\_CLOCK$  is a CMOS level the input frequency is limited to 200 MHz. This means the fastest the  $f_{OUT}$  pin can be toggled via the  $S\_CLOCK$  is 100 MHz as the divide ratio of the Post-PLL divider is 2 (if  $N = 1$ ). Note that the M counter output on the TEST output will not be a 50% duty cycle.

Table 10. Test and Debug Configuration for TEST

| T[2:0] |    |    | TEST Output                              |
|--------|----|----|--|
| T2     | T1 | T0 |  |
| 0      | 0  | 0  | 12-bit shift register out <sup>(1)</sup> |
| 0      | 0  | 1  | Logic 1                                  |
| 0      | 1  | 0  | $f_{XTAL} \div 2$                        |
| 0      | 1  | 1  | M-Counter out                            |
| 1      | 0  | 0  | $f_{OUT}$                                |
| 1      | 0  | 1  | Logic 0                                  |
| 1      | 1  | 0  | M-Counter out in PLL-bypass mode         |
| 1      | 1  | 1  | $f_{OUT} \div 4$                         |

1. Clocked out at the rate of S\_CLOCK.

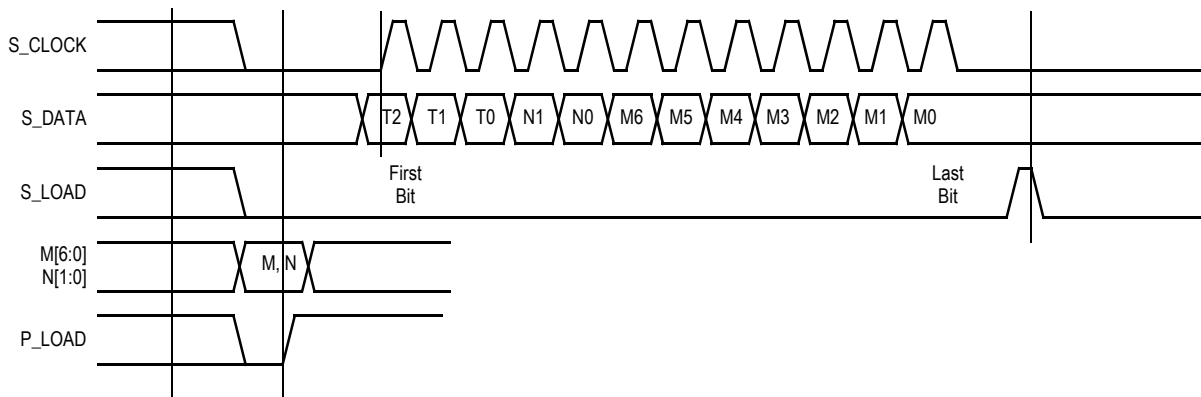

Figure 4. Serial Interface Timing Diagram

### Power Supply Filtering

The MPC9239 is a mixed analog/digital product. Its analog circuitry is naturally susceptible to random noise, especially if this noise is seen on the power supply pins. Random noise on the  $V_{CC\_PLL}$  pin impacts the device characteristics. The MPC9239 provides separate power supplies for the digital circuitry ( $V_{CC}$ ) and the internal PLL ( $V_{CC\_PLL}$ ) of the device. The purpose of this design technique is to try and isolate the high switching noise digital outputs from the relatively sensitive internal analog phase-locked loop. In a controlled environment such as an evaluation board, this level of isolation is sufficient. However, in a digital system environment where it is more difficult to minimize noise on the power supplies a second level of isolation may be required. The simplest form of isolation is a power supply filter on the  $V_{CC\_PLL}$  pin for the MPC9239. Figure 5 illustrates a typical power supply filter scheme. The MPC9239 is most susceptible to noise with spectral content in the 1 kHz to 1 MHz range. Therefore, the filter should be designed to target this range. The key parameter that needs to be met in the final filter design is the DC voltage drop that will be seen between the  $V_{CC}$  supply and the MPC9239 pin of the MPC9239. From the data sheet, the  $V_{CC\_PLL}$  current (the current sourced through the  $V_{CC\_PLL}$  pin) is maximum 20 mA, assuming that a minimum of 2.835 V must be maintained on the  $V_{CC\_PLL}$  pin. The resistor shown in Figure 5 must have a resistance of 10-15  $\Omega$  to meet the

Table 11. Debug Configuration for PLL Bypass<sup>(1)</sup>

| Output    | Configuration                |
|-----------|------------------------------|
| $f_{OUT}$ | $S\_CLOCK \div N$            |
| TEST      | M-Counter out <sup>(2)</sup> |

1. T[2:0] = 110. AC specifications do not apply in PLL bypass mode.
2. Clocked out at the rate of  $S\_CLOCK \div (2 \cdot N)$

voltage drop criteria. The RC filter pictured will provide a broadband filter with approximately 100:1 attenuation for noise whose spectral content is above 20 kHz. As the noise frequency crosses the series resonant point of an individual capacitor its overall impedance begins to look inductive and thus increases with increasing frequency. The parallel capacitor combination shown ensures that a low impedance path to ground exists for frequencies well above the bandwidth of the PLL. Generally, the resistor/capacitor filter will be cheaper, easier to implement and provide an adequate level of supply filtering. A higher level of attenuation can be achieved by replacing the resistor with an appropriate valued inductor. A 1000  $\mu$ H choke will show a significant impedance at 10 kHz frequencies and above. Because of the current draw and the voltage that must be maintained on the  $V_{CC\_PLL}$  pin, a low DC resistance inductor is required (less than 15  $\Omega$ ).

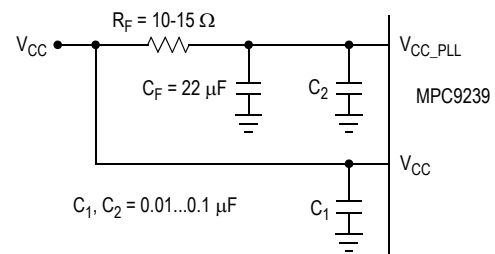
Figure 5.  $V_{CC\_PLL}$  Power Supply Filter



### Layout Recommendations

The MPC9239 provides sub-nanosecond output edge rates and thus a good power supply bypassing scheme is a must. Figure 6 shows a representative board layout for the MPC9239. There exists many different potential board layouts and the one pictured is but one. The important aspect of the layout in Figure 6 is the low impedance connections between  $V_{CC}$  and GND for the bypass capacitors. Combining good quality general purpose chip capacitors with good PCB layout techniques will produce effective capacitor resonances at frequencies adequate to supply the instantaneous switching current for the MPC9239 outputs. It is imperative that low inductance chip capacitors are used; it is equally important that the board layout does not introduce back all of the inductance saved by using the leadless capacitors. Thin interconnect traces between the capacitor and the power plane should be avoided and multiple large vias should be used to tie the capacitors to the buried power planes. Fat interconnect and large vias will help to minimize layout induced inductance and thus maximize the series resonant point of the bypass capacitors. Note the dotted lines circling the crystal oscillator connection to the device. The oscillator is a series resonant circuit and the voltage amplitude across the crystal is relatively small. It is imperative that no actively switching signals cross under the crystal as crosstalk energy coupled to these lines could significantly impact the jitter of the device. Special attention should be paid to the layout of the crystal to ensure a stable, jitter free interface between the crystal and the on-board oscillator. Although the MPC9239 has several design features to minimize the susceptibility to power supply noise (isolated power and grounds and fully differential PLL), there still may be applications in which overall performance is being degraded due to system power supply noise. The power supply filter and bypass schemes discussed in this section should be adequate to eliminate power supply noise related problems in most designs.

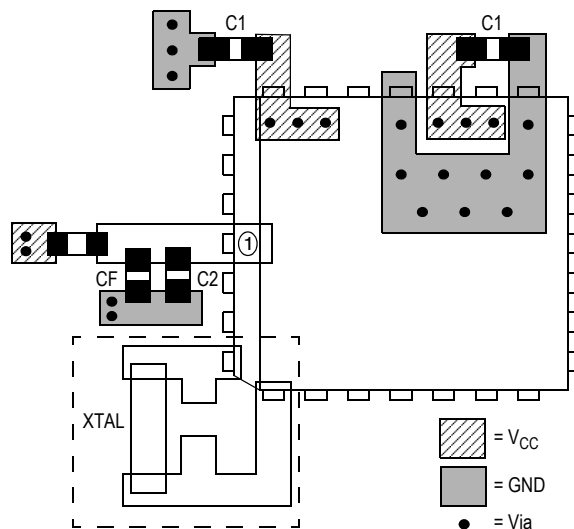

Figure 6. PCB Board Layout Recommendation for the PLCC28 Package

### Using the On-Board Crystal Oscillator

The MPC9239 features a fully integrated on-board crystal oscillator to minimize system implementation costs. The oscillator is a series resonant, multivibrator type design as opposed to the more common parallel resonant oscillator design. The series resonant design provides better stability and eliminates the need for large on chip capacitors. The oscillator is totally self contained so that the only external component required is the crystal. As the oscillator is somewhat sensitive to loading on its inputs the user is advised to mount the crystal as close to the MPC9239 as possible to avoid any board level parasitics. To facilitate co-location surface mount crystals are recommended, but not required. Because the series resonant design is affected by capacitive loading on the XTAL terminals loading variation introduced by crystals from different vendors could be a potential issue. For crystals with a higher shunt capacitance it may be required to place a resistance across the terminals to suppress the third harmonic. Although typically not required it is a good idea to layout the PCB with the provision of adding this external resistor. The resistor value will typically be between 500 and 1K $\Omega$ .

The oscillator circuit is a series resonant circuit and thus for optimum performance a series resonant crystal should be used. Unfortunately most crystals are characterized in a parallel resonant mode. Fortunately there is no physical difference between a series resonant and a parallel resonant crystal. The difference is purely in the way the devices are characterized. As a result a parallel resonant crystal can be used with the MPC9239 with only a minor error in the desired frequency. A parallel resonant mode crystal used in a series resonant circuit will exhibit a frequency of oscillation a few hundred ppm lower than specified, a few hundred ppm translates to kHz inaccuracies. In a general computer application this level of inaccuracy is immaterial. Table 12 below specifies the performance requirements of the crystals to be used with the MPC9239.

Table 12. Recommended Crystal Specifications

| Parameter                          | Value                   |
|------------------------------------|-------------------------|
| Crystal Cut                        | Fundamental AT Cut      |
| Resonance                          | Series Resonance*       |
| Frequency Tolerance                | $\pm 75$ ppm at 25°C    |
| Frequency/Temperature Stability    | $\pm 150$ ppm 0 to 70°C |
| Operating Range                    | 0 to 70°C               |
| Shunt Capacitance                  | 5-7 pF                  |
| Equivalent Series Resistance (ESR) | 50 to 80 $\Omega$       |
| Correlation Drive Level            | 100 $\mu$ W             |
| Aging                              | 5ppm/Yr (First 3 Years) |

\* See accompanying text for series versus parallel resonant discussion.

PACKAGE DIMENSIONS

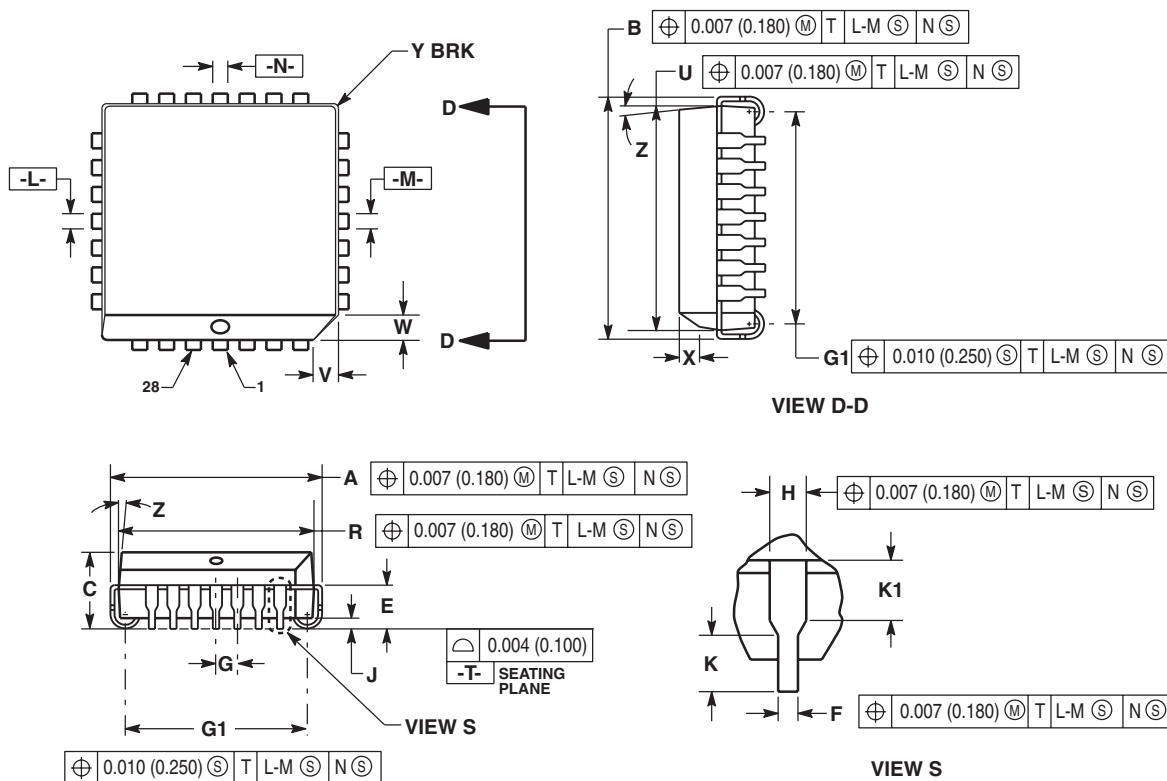

NOTES:

- DATUMS -L-, -M-, AND -N- DETERMINED WHERE TOP OF LEAD SHOULDER EXISTS PLASTIC BODY AT MOLD PARTING LINE.
- DIMENSION G1, TRUE POSITION TO BE MEASURED AT DATUM -T-, SEATING PLANE.
- DIMENSIONS R AND U DO NOT INCLUDE MOLD FLASH. ALLOWABLE MOLD FLASH IS 0.010 (0.250) PER SIDE.
- DIMENSIONING AND TOLERANCING PER ANSI Y14.5M, 1982.
- CONTROLLING DIMENSION: INCH.
- THE PACKAGE TOP MAY BE SMALLER THAN THE PACKAGE BOTTOM BY UP TO 0.012 (0.300). DIMENSIONS R AND U ARE DETERMINED AT THE OUTERMOST EXTREMES OF THE PLASTIC BODY EXCLUSIVE OF MOLD FLASH, TIE BAR BURRS, GATE BURRS AND INTERLEAD FLASH, BUT INCLUDING ANY MISMATCH BETWEEN THE TOP AND BOTTOM OF THE PLASTIC BODY.
- DIMENSION H DOES NOT INCLUDE DAMBAR PROTRUSION OR INTRUSION. THE DAMBAR PROTRUSION(S) SHALL NOT CAUSE THE H DIMENSION TO BE GREATER THAN 0.037 (0.940). THE DAMBAR INTRUSION(S) SHALL NOT CAUSE THE H DIMENSION TO BE SMALLER THAN 0.025 (0.635).

| DIM | INCHES    |       | MILLIMETERS |       |
|-----|-----------|-------|-------------|-------|
|     | MIN       | MAX   | MIN         | MAX   |
| A   | 0.485     | 0.495 | 12.32       | 12.57 |
| B   | 0.485     | 0.495 | 12.32       | 12.57 |
| C   | 0.165     | 0.180 | 4.20        | 4.57  |
| E   | 0.090     | 0.110 | 2.29        | 2.79  |
| F   | 0.013     | 0.019 | 0.33        | 0.48  |
| G   | 0.050 BSC |       | 1.27 BSC    |       |
| H   | 0.026     | 0.032 | 0.66        | 0.81  |
| J   | 0.020     | ---   | 0.51        | ---   |
| K   | 0.025     | ---   | 0.64        | ---   |
| R   | 0.450     | 0.456 | 11.43       | 11.58 |
| U   | 0.450     | 0.456 | 11.43       | 11.58 |
| V   | 0.042     | 0.048 | 1.07        | 1.21  |
| W   | 0.042     | 0.048 | 1.07        | 1.21  |
| X   | 0.042     | 0.056 | 1.07        | 1.42  |
| Y   | ---       | 0.020 | ---         | 0.50  |
| Z   | 2"        | 10"   | 2"          | 10"   |
| G1  | 0.410     | 0.430 | 10.42       | 10.92 |
| K1  | 0.040     | ---   | 1.02        | ---   |

CASE 776-02  
ISSUE D  
28-LEAD PLCC PACKAGE

PACKAGE DIMENSIONS

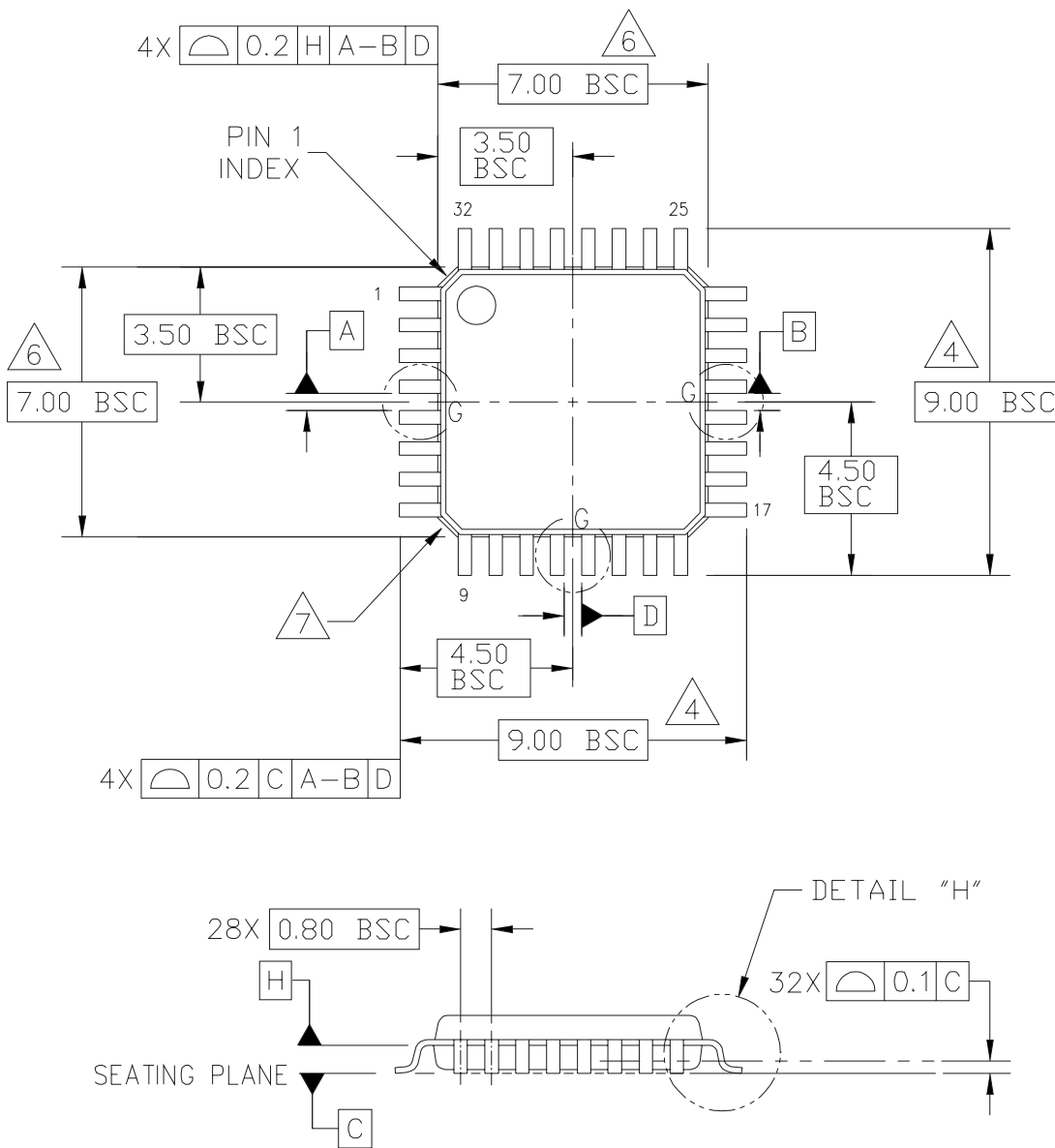

|   |                            |                            |
|---|----------------------------|----------------------------|
| © FREESCALE SEMICONDUCTOR, INC.<br>ALL RIGHTS RESERVED.                         | MECHANICAL OUTLINE         | PRINT VERSION NOT TO SCALE |
| TITLE:<br>LOW PROFILE QUAD FLAT PACK (LQFP)<br>32 LEAD, 0.8 PITCH (7 X 7 X 1.4) | DOCUMENT NO: 98ASH70029A   | REV: C                     |
|   | CASE NUMBER: 873A-04       | 01 APR 2005                |
|   | STANDARD: JEDEC MS-026 BBA |                            |

**CASE 873A-04  
ISSUE C  
32-LEAD LQFP PACKAGE**

PACKAGE DIMENSIONS

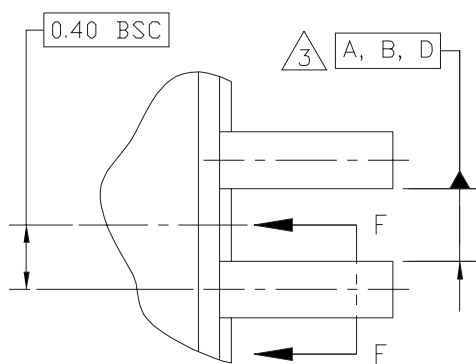

DETAIL G

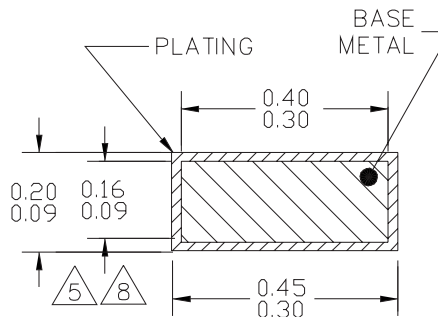

⊕ 0.2 Ⓜ C A-B D

SECTION F-F  
ROTATED 90°CW  
32 PLACES

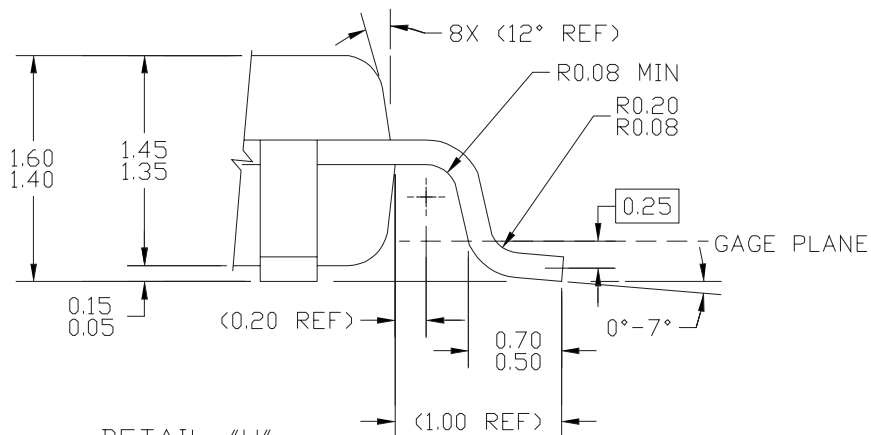

DETAIL "H"

|   |                            |                            |  |
|---|----------------------------|----------------------------|--|
| © FREESCALE SEMICONDUCTOR, INC.<br>ALL RIGHTS RESERVED.                         | MECHANICAL OUTLINE         | PRINT VERSION NOT TO SCALE |  |
| TITLE:<br>LOW PROFILE QUAD FLAT PACK (LQFP)<br>32 LEAD, 0.8 PITCH (7 X 7 X 1.4) | DOCUMENT NO: 98ASH70029A   | REV: C                     |  |
|   | CASE NUMBER: 873A-04       | 01 APR 2005                |  |
|   | STANDARD: JEDEC MS-026 BBA |                            |  |

**CASE 873A-04  
ISSUE C  
32-LEAD LQFP PACKAGE**

## PACKAGE DIMENSIONS

## NOTES:

1. DIMENSIONS ARE IN MILLIMETERS.
2. INTERPRET DIMENSIONS AND TOLERANCES PER ASME Y14.5-1994.
3. DATUMS A, B, AND D TO BE DETERMINED AT DATUM PLANE H.
4. DIMENSIONS TO BE DETERMINED AT SEATING PLANE DATUM C.
5. DIMENSION DOES NOT INCLUDE DAMBAR PROTRUSION. ALLOWABLE DAMBAR PROTRUSION SHALL NOT CAUSE THE LEAD WIDTH TO EXCEED THE MAXIMUM DIMENSION BY MORE THAN 0.08 MM. DAMBAR CANNOT BE LOCATED ON THE LOWER RADIUS OR THE FOOT. MINIMUM SPACE BETWEEN PROTRUSION AND ADJACENT LEAD OR PROTRUSION: 0.07 MM.
6. DIMENSIONS DO NOT INCLUDE MOLD PROTRUSION. ALLOWABLE PROTRUSION IS 0.25 MM PER SIDE. DIMENSIONS ARE MAXIMUM PLASTIC BODY SIZE DIMENSIONS INCLUDING MOLD MISMATCH.
7. EXACT SHAPE OF EACH CORNER IS OPTIONAL.
8. THESE DIMENSIONS APPLY TO THE FLAT SECTION OF THE LEAD BETWEEN 0.1 MM AND 0.25 MM FROM THE LEAD TIP.

|   |                            |                            |  |
|---|----------------------------|----------------------------|--|
| © FREESCALE SEMICONDUCTOR, INC.<br>ALL RIGHTS RESERVED.                         | MECHANICAL OUTLINE         | PRINT VERSION NOT TO SCALE |  |
| TITLE:<br>LOW PROFILE QUAD FLAT PACK (LQFP)<br>32 LEAD, 0.8 PITCH (7 X 7 X 1.4) | DOCUMENT NO: 98ASH70029A   | REV: C                     |  |
|   | CASE NUMBER: 873A-04       | 01 APR 2005                |  |
|   | STANDARD: JEDEC MS-026 BBA |                            |  |

PAGE 3 OF 3

**CASE 873A-04  
ISSUE C  
32-LEAD LQFP PACKAGE**

Innovate with IDT and accelerate your future networks. Contact:

**www.IDT.com**

**For Sales**

800-345-7015  
408-284-8200  
Fax: 408-284-2775

**For Tech Support**

netcom@idt.com  
480-763-2056

---

**Corporate Headquarters**

Integrated Device Technology, Inc.  
6024 Silver Creek Valley Road  
San Jose, CA 95138  
United States  
800 345 7015  
+408 284 8200 (outside U.S.)

**Asia Pacific and Japan**

Integrated Device Technology  
Singapore (1997) Pte. Ltd.  
Reg. No. 199707558G  
435 Orchard Road  
#20-03 Wisma Atria  
Singapore 238877  
+65 6 887 5505

**Europe**

IDT Europe, Limited  
Prime House  
Barnett Wood Lane  
Leatherhead, Surrey  
United Kingdom KT22 7DE  
+44 1372 363 339